

Air-hydraulic Autolift



Technical Data

Model	L20PH	
Capacity	kg	2000
Min. height	mm	115
Max. height	mm	910
Lifting speed, approx.	sek.	60
Net weight, lift	kg	193
Net weight, box	kg	32
Air pressure	bar	7-12

- Supreme accessibility and working height – for brake and body repairs, wheel change, sanding and filling, reassembly etc.
- All operations are controlled from the control box.
- Stable support arms adjustable in all directions.
- Saddle height adjustable up to 58 mm.
- Long life time with greasing nipples in all hinges. The cylinder is protected by a metal cap.
- No additional costs for installment.
- Easy to move with the trolley.

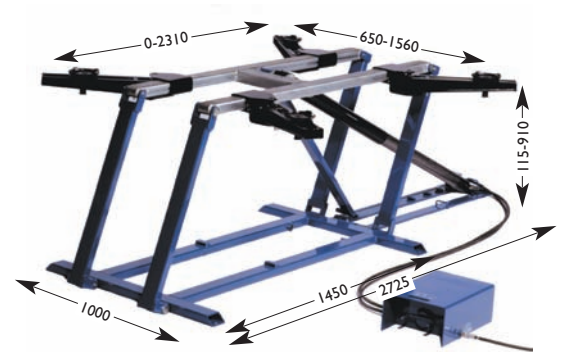

All operations are controlled by single pedal on portable control box.

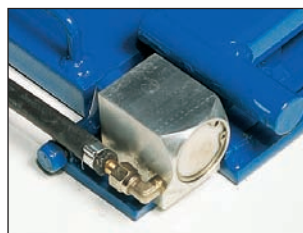

The automatic safety stop is also released by remote control from the control box. Protected against overloading and hose burst.

Option:



Saddle
36 014 00: Saddle cushions for protection of car body and anti-rust coating.

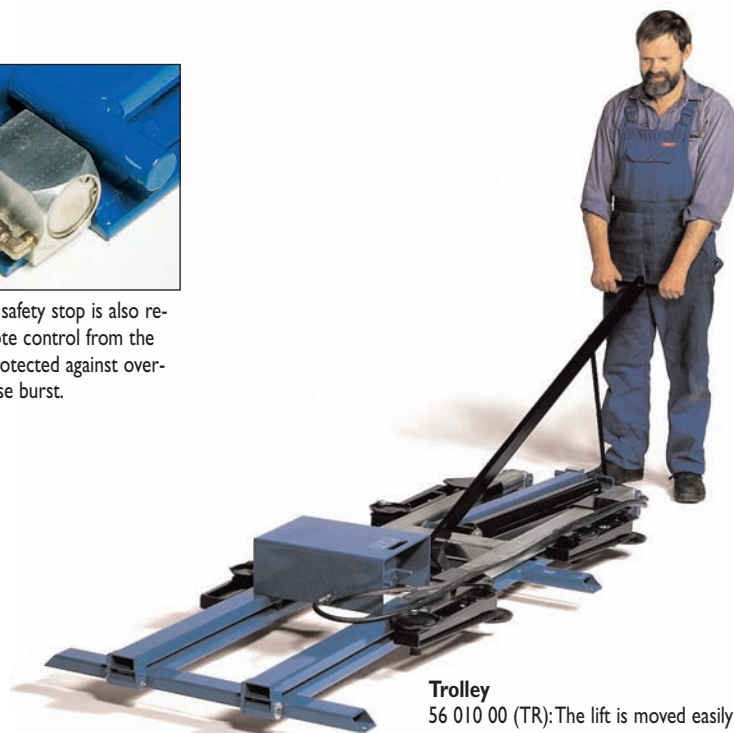

Trolley
56 010 00 (TR): The lift is moved easily and quickly with the trolley. (Option)